

CAVITATIONAL IRON MICROPARTICLES GENERATION BY PLASMA PROCEDURES FOR MEDICAL APPLICATIONS

Ioan Bica¹, Madalin Bunoiu¹, Liviu Chirigiu², Marius Spunei¹, Iulius Juganaru¹

¹*West University of Timisoara, Faculty of Physics, Timisoara, Romania*

²*Faculty of Pharmacy, University of Medicine and Pharmacy, Craiova, Romania.*

Article Info

Received: 28 December 2011

Accepted: 9 January 2012

Keywords: Iron microparticles, microspheres, pores, octopus-shaped microparticles, plasma, microtubes.

Abstract

The paper presents the experimental installation for the production, in argon plasma, of cavitational iron microparticles (pore microspheres, microtubes and octopus-shaped microparticles). Experimental results are presented and discussed and it is shown that adsorbant particles with a minimum iron content are obtained by the plasma procedures

1. Introduction

Diagnosing and therapy of a number of diseases can be also achieved by the use of ferri - ferromagnetic microparticles. Refs. [1-5] show the advances as well as the limits to magnetic microparticles applicability in medicine. Relatively recent research has revealed that iron microparticles having ad/adsorbant properties are of interest for the magnetically controlled transport of anticancer drugs in tumor [6], magnetic hemosorption [7] etc.

Absorbant iron microparticles are of the Ferro-Carbon-4 type [6-8]. They are obtained by the oxidoreduction reaction of iron oxides in the presence of carbon, followed by the formation of an iron nucleus on which carbon is deposited as nanotubes [6]. The quantity of iron in the nucleus of the adsorbant microparticle is an essential parameter in the control of the toxicity of the anticancer therapy with adsorbent iron microparticles [7, 8].

Transport of substances in general and that of drugs in particular can also be achieved by means of cavitational microparticles, namely: pore microspheres [9, 10], microtubes [11] and octopus-shaped microparticles [12].

In what follows, we set ourselves to describe the procedure for obtaining cavitational microparticles in plasma and to show that by the plasma procedure the quantity of iron can be controlled.

2. Experimental installation

The overall configuration of the installation for the production of cavitation micro-particles by plasma procedures is the one shown in Fig.1.a. The installation includes the plasma generator A, the current source B, the material advance system C, the material fixing-positioning system P, and the plasmagen gas storage area (G).

The plasma generator shows laminary stabilization. The power source has a descending characteristic (Fig.1.b). The idle operation voltage is $260 V_{dc} \pm 5\%$. It yields a current through the electric arc, which is continually adjustable between $70 A_{dc} \pm 10\%$ and $350 A_{dc} \pm 5\%$. The material advance system together with the material fixing-positioning system allows the uniform insertion of material in the plasma and the positioning of the electrode rod (pos. 3 in Fig.1.a). The advance velocity of the electrode rod can be continually adjusted between $0.20 \times 10^{-3} \text{ m/s} \pm 1\%$ and $1.5 \times 10^{-3} \text{ m/s} \pm 1\%$.

By means of device P, the angle of incidence of the electrode rod and the plasma jet can be adjusted between $\pi/6$ rad and $\pi/2$ rad and the distance δ between $1.5 \times 10^{-3} \text{ m} \pm 1\%$ and $25 \times 10^{-3} \text{ m} \pm 2\%$. The plasma generator can function as plasma jet (closed K contact) or as transferred arc (open K contact).

The plasmagen gas storage area consists of argon tubes (150 bar). A pressure reductor (150 bar/1.5 bar) with flowmeter has been mounted on each plasmagen gas tube. The argon flow can be continually adjusted between $0.10 \times 10^{-3} \text{ m}^3/\text{s} \pm 5\%$ and $60 \times 10^{-3} \text{ m}^3/\text{s} \pm 2\%$.

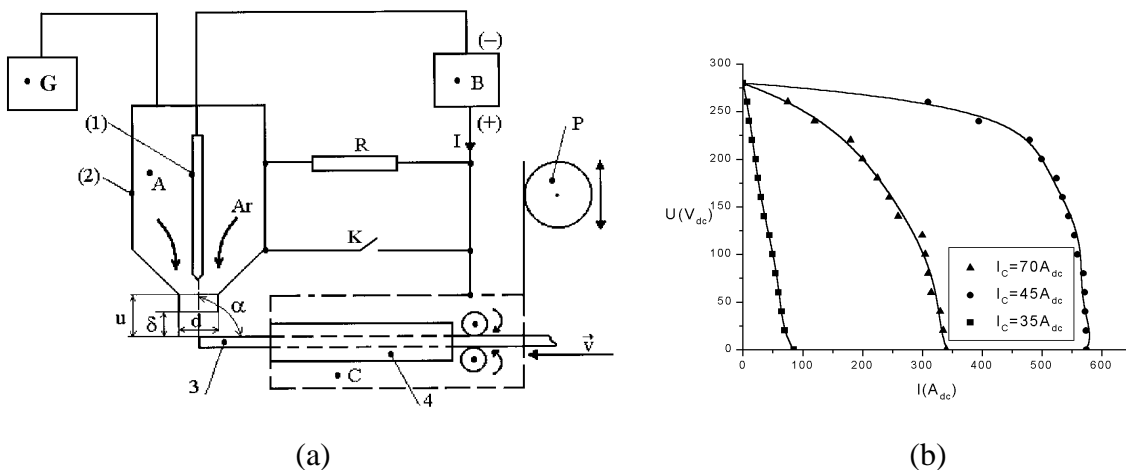

Fig.1. (a) Overall configuration of the installation utilized for iron micro-tube production in plasma: A-plasma generator; B-current source; C-material advance system; P-positioning-fixing system for material; 1-cathode; 2-nozzle; 3-material (carbon steel rod); 4-contact nozzle cooled with water; d-nozzle diameter; δ -nozzle – material distance; α -attack (incidence) angle; v -material advance speed; I -current intensity; U -tension on arc; K-switch; \curvearrowright Ar-argon admission; \longleftrightarrow -rod advance direction; \updownarrow rod up-down positioning. (b) Static characteristics of the power source for various values of the command current I_c of the magnetic amplifier.

3. Experimental result and discussion

The installation in Fig.1.a is used for the production of cavitation micro particles in plasma. The material from which cavitation micro particles are obtained in plasma is a carbon steel rod.

The diameter d_e of the rod is $3 \times 10^{-3} \text{ m} \pm 10\%$. The chemical composition of the steel (% mass) is C: 0.19; Mn: 10.85; P: 0.045; S: 0.045; Si: 0.40; Fe: 88.47. The plasma generator has a nozzle of diameter $d=2.0 \times 10^{-3} \text{ m}$. The distance between the nozzle of the plasma generator and the rod is fixed at $\delta=6.0 \times 10^{-3} \text{ m}$ and $\alpha=\pi/2 \text{ rad}$ (Fig.1.a).

The intensity of the electric current through the plasma arc transferred onto the electrode rod is $I=175 \text{ A}_{dc}$. The velocity v of the rod and the argon flow D are values which change during the experiment. At $v=1.25 \times 10^{-3} \text{ m/s}$ and $D=0.35 \times 10^{-3} \text{ m}^3/\text{s}$, parts of the rod melt. The melt, in continuous flow, is transported by the plasma gas. By solidification, a compact mass is obtained. By increasing the advance velocity of the rod to $v=1.10 \times 10^{-3} \text{ m/s}$, iron micro particles and solidified melt are obtained (Fig.2.a).

We hold the advance velocity of the rod at the same value. But when we increase the argon flow to $1.00 \times 10^{-3} \text{ m}^3/\text{s}$, 95% iron micro particles result (Fig.2.b). One can see through the optic microscope that some of micro particles have pores, as shown in Fig.2.c. Analysis of about 450 particles shows that 35% are pore microspheres. The mean microsphere has its diameter of $10 \mu\text{m}$ and its wall thickness of $0.75 \mu\text{m}$.

At $v=1.25 \times 10^{-3} \text{ m/s}$ and $D=0.65 \times 10^{-3} \text{ m}^3/\text{s}$, there result micro particles, microspheres and, respectively, about 15% micro particles having a central nucleus (microsphere) out of which ligaments stick in the same plan. In Fig.3 one can see that the ligaments are empty. The particles displaying such shapes will be referred to by us as octopus-shaped micro particles. The mean sizes of the octopus-shaped micro particles are:

- for the nucleus (mean diameter: $12 \mu\text{m}$ and wall thickness: $0.5 \mu\text{m}$) and,

- for the ligaments (length: $188 \mu\text{m}$, equivalent diameter: $2 \mu\text{m}$ and wall thickness: $0.35 \mu\text{m}$).

At $v=1.15 \times 10^{-3} \text{ m/s}$ and $D=0.75 \times 10^{-3} \text{ m}^3/\text{s}$, a movement of the melt is noticed in the plasma as continuous and parallel lines. Following solidification, fibers result as those in Fig.4.a. Seen on the optic microscope, they appear like micro tubes of shapes and sizes as shown in Figs. 4b-4d. The mean micro tube is characterized by: length: $100 \mu\text{m}$; diameter: $3 \mu\text{m}$ and wall thickness: $0.25 \mu\text{m}$.

The cavitation micro particles (Figs. 2, 3 and 4) have their surface covered with Fe_3O_4 (Fig.5). The presence of Fe_3O_4 is due to the oxygen traces in the technical argon.

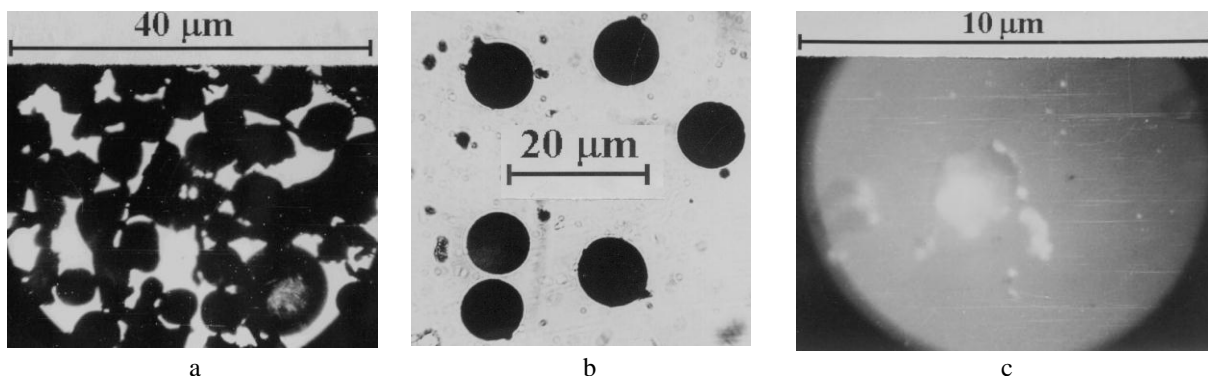

Fig.2. Shapes and sizes of the iron microparticles: a. microparticles, microspheres and melted iron mass; b. microparticles and microspheres; c. pore microspheres.

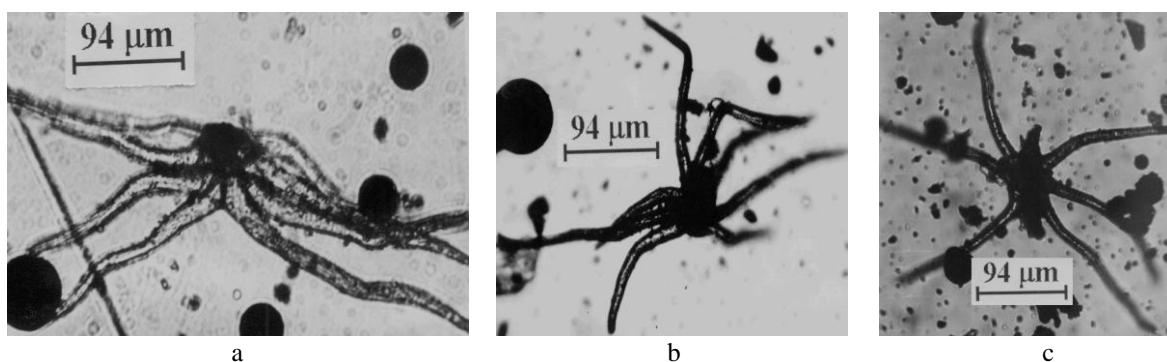

Fig.3. Octopus-shaped iron microparticles

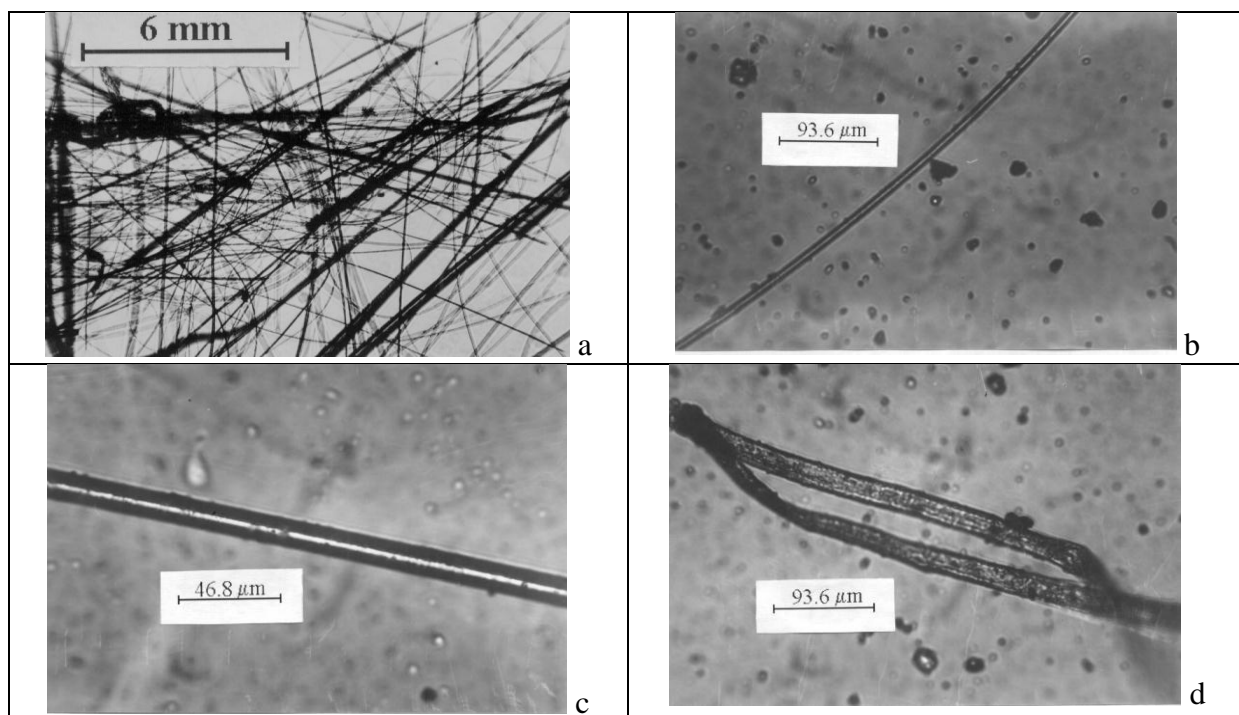

Fig.4. Iron fibres (a) and iron microtubes (b,c,d)

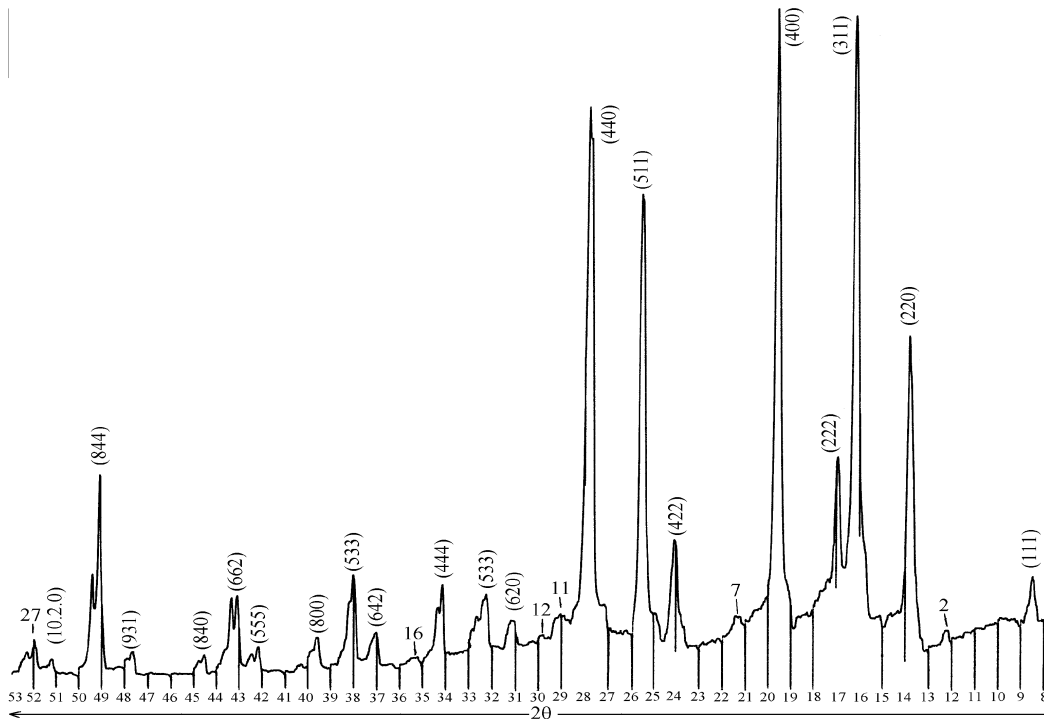

Fig.5. X-ray diffraction patterns of iron cavitation microparticles

450 cavitation microparticles are considered. The mean volume occupied by the iron layer is calculated. Further, the volume occupied by the liquid is determined and the iron concentration contained by a mean cavitation microparticle is calculated. The results obtained are those in Table 1.

Table 1. Volume concentration of iron in the cavitation microparticles

Type of microparticle	Microsphere	Microtube	Octopus-Shaped microparticles
Volume Concentration (%)	~12	~35	~10

Conclusions

The installation in Fig.1.a allows obtaining microparticles in general and cavitation microparticles in particular;

By maintaining the discharge current at constant values, cavitation microparticles are obtained by modifying the argon flow and, respectively, the material advance velocity;

The iron concentration of the microparticles can be controlled by using the plasma procedure (Table 1).

References

1. T. Nakamura, Magnetomedicine-characteristics of fine ferromagnetic particles. *J. Appl. Phys.* 42 (1971), 1320-1324;
2. A. Senyei, K. Reich, C. Conezy, K. Widder. In vivo kinetics of magnetically targeted low-dose dexamethasone. *J. Pharm. Science* 70 (1991), 383-391;
3. K. Widder, A. Senyei. Magnetic microspheres: a vehicle for selective targeting of drugs. *J. Pharm. Therapy* 20 (1983), 377-396;
4. V. M. Chikov, A. A. Kuznetsov, W. Schütt. Analytical cell magnetophoresis. In: *Physical characterization of biological cells*. Verlag Gesundheit GmbH Berlin (1991), pp. 381-389;
5. A. A. Kuznetsov, V. M. Chikov, A. M. Shapiro, S. Winoto-Morbach, W. Müller-Rucholtz. Single cell magnetophoresis and its diagnostic value. *J.Magn.Magn. Mater.* 122 (1993), 367-370;
6. A. A. Kuznetsov, A. R. Harutyunyan, E. K. Dobrinsky, V. I. Filippov, A. G. Malenkov, A. F. Vanin, O. A. Kuznetsov, Ferro-carbon particles: Preparation and Clinical Applications. In: *Scientific and Clinical Applications of Magnetic Carriers*. Ed. by Häfeli et al. Plenum Press. New-York, 1997, pp. 379-389;
7. A. A. Kuznetsov, V. I. Filippov, O. A. Kuznetsov, V. G. Gerlivanov, E. K. Dobrinsky, S. I. Malashin. New ferro-carbon adsorbants for magnetically guided transport of anti-cancer drugs. *J.Magn.Magn. Mater.* 194 (1999), 22-30;
8. U. O. Häfeli, G.J.Pauer. In vitro and vivo toxicity of magnetic microspheres. *J.Magn.Magn. Mater.* 194 (1999), 76-82;
9. I. Bica. On the mechanisms of iron microspheres formation in argon plasma jet. *J.Magn.Magn. Mater.* 257 (2003), 119-125;
10. I. Bica. Pore formation in iron microspheres by plasma procedure. *Mater. Sci. Eng.* A 303 (2005), 191-195;
11. I. Bica. Formation of iron microtubes in plasma. *J.Magn.Magn.Mater.* 270,1-2 (2004), 7-14;
12. I. Bica. Some mechanisms for the formation of octopus-shaped iron microparticles. *J.Magn.Magn. Mater.* 279, 2-3 (2004), 289-298;