

**ABOUT THE FIRST EXPERIMENT AT JINR NUCLOTRON DEUTERON BEAM  
WITH ENERGY 2.52 GEV ON INVESTIGATION OF TRANSMUTATION OF I-129,  
NP-237, PU-238 AND PU-239 IN THE FIELD OF NEUTRONS GENERATED IN PB-  
TARGET WITH U-BLANKET**

S. Jokić<sup>1</sup>, N. Čitaković<sup>1</sup>, M.I. Krivopustov<sup>2</sup>, A.V. Pavliouk<sup>2</sup>, I.I. Mariin<sup>2</sup>, A.F. Elishev<sup>2</sup>,  
J. Adam<sup>2</sup>, Yu.A. Batusov<sup>2</sup>, P.Chaloun<sup>2</sup>, V.G. Kalinnikov<sup>2</sup>, V.B.Brudanin<sup>2</sup>, A.A. Solnyshkin<sup>2</sup>,  
V.I. Stegailov<sup>2</sup>, V.M. Tsoupko-Sitnikov<sup>2</sup>, K. Katovský<sup>3</sup>, R. Brandt<sup>4</sup>, W. Ensinger<sup>4</sup>,  
H. Robotham<sup>4</sup>, W. Westmeier<sup>4</sup>, O. Svoboda<sup>5</sup>, Z. Dubnička<sup>5</sup>, M. Kála<sup>5</sup>, M. Kloc<sup>5</sup>, A. Krása<sup>5</sup>, A.  
Kugler<sup>5</sup>, M. Majerle<sup>5</sup>, V. Wagner<sup>5</sup>, M. Bielewicz<sup>6</sup>, S. Kilim<sup>6</sup>, M. Szuta<sup>6</sup>, E. Strugalska-Gola<sup>6</sup>,  
A. Wojeciechowski<sup>6</sup>, S.R. Hashemi-Nezhad<sup>7</sup>, M. Manolopoulou<sup>8</sup>, M. Fragopoulou<sup>8</sup>,  
S. Stoulos<sup>8</sup>, M. Zamani-Valasiadou<sup>8</sup>, I.V.Zhuk<sup>9</sup>, A.S. Potapenko<sup>9</sup>, J.P.Lukashevich<sup>9</sup>,  
A.Voronko<sup>10</sup>, V.V.Sotnikov<sup>10</sup>, V.V.Sidorenko<sup>10</sup>, P. Jivkov<sup>11</sup>, L. Kostov<sup>11</sup>, Ch.Stoyanov<sup>11</sup>,  
Ts. Damdinsuren<sup>12</sup>, G.Gansorig<sup>12</sup>, S. Gerbish<sup>12</sup>, Ts. Togoo<sup>12</sup>, V. Kumar<sup>13</sup>, H. Kumawat<sup>13</sup>

<sup>1</sup>Vinca Institute of Nuclear Sciences, Belgrade, Serbia, <sup>2</sup>Joint Institute for Nuclear Research, Dubna, Russia,  
<sup>3</sup>Czech Technical University in Prague, Czech Republic, <sup>4</sup>Philipps-Universität, Marburg, Germany, <sup>5</sup>Nuclear  
Physics Institute, Řež, Czech Republic, <sup>6</sup>Institute of Atomic Energy, Otwock-Swierk, Poland, <sup>7</sup>University,  
Department of High Energy Physics, Sydney, Australia, <sup>8</sup>Aristotle University, Thessaloniki, Greece, <sup>9</sup> Joint  
Institute of Power and Nuclear Research-Sosny, Minsk, Belarus, <sup>10</sup>Kharkovsky Physics-Technical Institute,  
Kharkov, Ukraine, <sup>11</sup>Institute Nuclear Research and Nuclear Energetic, Sofia, Bulgaria, <sup>12</sup>National University,  
UlanBator, Mongolia, <sup>13</sup>University of Rajasthan, Jaipur, India

**Abstract**

The experiment described in this communication is a part of the scientific program „Investigations of physical aspects of electronuclear method of energy production and transmutation of radioactive waste of atomic energetic using relativistic beams from the JINR Synchrotron/Nuclotron“ - the project „Energy plus Transmutation“. The performing of the first experiment at deuteron beam with energy 2.52 GeV at the electronuclear setup which consists of Pb-target with U-blanket (206.4 kg of natural uranium) and transmutation samples and its preliminary results are described. The hermetic samples of isotopes of I-129, Np-237, Pu-238 and Pu-239 which are produced in atomic reactors and industry setups which use nuclear materials and nuclear technologies were irradiated in the field of electronuclear neutrons produced in the Pb-target surrounded with the U-blanket setup “Energy plus transmutation”. The estimations of its transmutations (radioecological aspect) were obtained in result of measurements of gamma activities of these samples. The information about space-energy distribution of neutrons in the volume of the Pb-target and the U-blanket was obtained with help of sets of activation threshold detectors (Al, V, Cu, Co, Y, In, I, Ta, Au, W, Bi and other), solid state nuclear track detectors, He-3 neutron detectors and nuclear emulsions.

**Keywords:** transmutation, radioactive waste, spallation.

## **1. Introduction (Time New Roman 12pt. Bold)**

The project is called “Energy plus Transmutation” (see Krivopustov et al. [1-4]). Scientific description of the project, including main ideas, history, performed experiments’ description and results, uranium calorimeter description, experimental methodology used for neutron and proton field properties investigation (activation and solid state nuclear track detectors, nuclear emulsions, He-3 detectors, thresholds detectors, etc.), could be found in the publications of the “Energy plus Transmutation” collaboration [3-8] and in the overview of JINR research by Baldin, Malakhov and Syssakian [9a]. During 1999-2004 various experiments were held with “Energy plus Transmutation” assembly with proton beams in the range of energies from 0.7 GeV to 2.0 GeV. The experiments were focused on general aspects of energy generation by future Accelerator Driven Systems (ADS), e.g., neutron generation and multiplication, neutron spectra determination, generation of secondary isotopes inside Pb-target and U-blanket, energy generation and deposition, neutron induced transmutation of long-lived minor-actinides ( $^{237}\text{Np}$ ,  $^{241}\text{Am}$ ), fission products ( $^{129}\text{I}$ ), and plutonium isotopes ( $^{238,239}\text{Pu}$ ) [3-17]. These investigations appear to be very important for development of ADS usable for future nuclear energy utilization and nuclear fuel cycle safety. This technology has recently attracted considerable attention [18-25]. The use of the deuteron beam was motivated by the possibility of comparison of the data of neutron generation in our set-up with data of Tolstov [24], who used Pb-slot of  $50 \times 50 \times 80 \text{ cm}^3$ , and Vassilkov [25], who used the cylinder with diameters from 16 to 20 cm and length from 60 to 76 cm. This paper describes the experiment with deuteron beam with energy of 2.52 GeV, which was held in JINR Dubna, on 30<sup>th</sup> November 2005 using superconductivity accelerator Nuclotron by Vexler and Baldin Laboratory High Energies (see Kovalenko et al. [9b])

## **2. Experimental setup**

General scheme of “Energy plus Transmutation” facility [2-6], which was built in 1998-1999 for spending fuel isotopes is given in figs 1 and 2. The detailed technical design was carried out by the All-Russian Institute of Nuclear Energy Machine Building (VNIIAM) in Moscow and manufacturing of the steel structure was performed at the mechanical workshop of the LHE JINR. The “Energy plus Transmutation” setup consists of the following system:

- Lead target divided into four sections (diameter of 84 mm and length of 456 mm, weight of 28.6 kg).

- Uranium blanket also divided into four sections; each section consists of 30 fuel rods of natural uranium inside the aluminium cover (34 mm diameter, 104 mm length, weight of 1.72 kg). Each section contains 51.6 kg of uranium, so the whole blanket contains 206.4 kg of natural uranium.
- Beam monitoring system of activation and solid state detectors and proportional ionization chambers.
- He-3 detector system. This kind of detectors was used to determine spatial and energy distributions of neutron fluence [26].
- Set of radioactive samples for transmutation studies. This set contains  $^{129}\text{I}$ ,  $^{237}\text{Np}$ ,  $^{238}\text{Pu}$ , and  $^{239}\text{Pu}$ . Each isotope was hermetically packed inside the duralumin container .
- Backplate for radioactive samples and other foil-based detectors fixation to the top of the 2<sup>nd</sup> section of the uranium blanket (fig. 1).
- Five plates for activation detectors and Solid State Nuclear Track Detectors (SSNTD) fixation made from special polyethylene-foil
- Five spectrometers based on nuclear emulsions for neutron registration by proton recoils [5].
- Set of thermometers (thermocouples, thermoresistors, etc.) for determination of the heat generation inside the uranium blanket [3].
- Shielding box made from granulated polyethylene with boron carbide, with a cadmium cover and the outside box made from wood. Box has the dimensions of 100x106x111 cm and weight of 950 kg and can be moved to the irradiation place (focus F3N of the Nuclotron experimental complex) using special rail system. System of activation and threshold detectors, nuclear emulsion, SSNTD, He-3 detectors, and thermal detector system [3,5,13] are in general called uranium fission calorimeter [3].

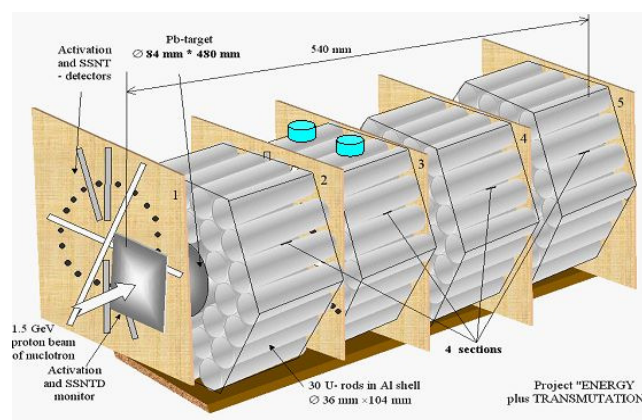

*Fig. 1. Scheme of the four-section “Energy plus Transmutation” setup with a massive lead target and uranium blanket [3-5].*

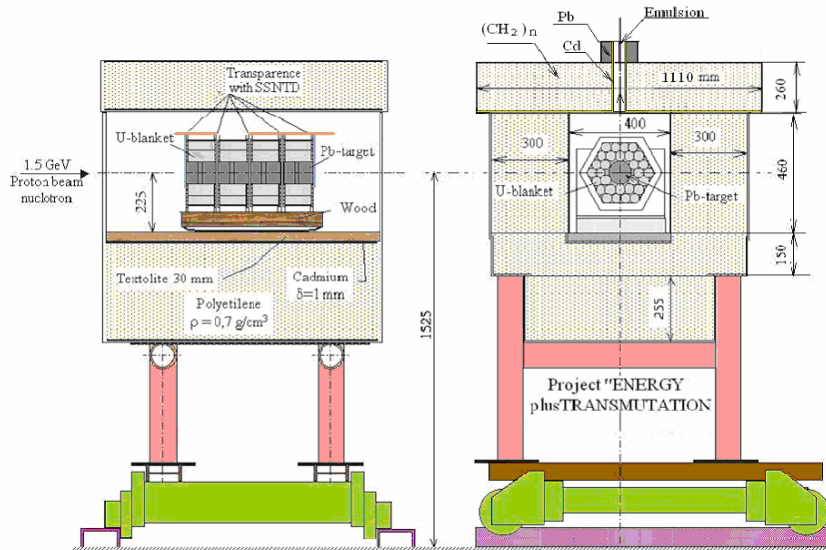

Fig 2. Technical details of the U/Pb-assembly inside a massive shielding and placed into a mobile platform, which can be moved into and out of the beam line. The left side of this figure gives a cross section of the assembly along the deuteron beam line, the right-side shows a cut through the assembly perpendicular to the deuteron beam line in the position [3-5].

### 3. Transmutation samples

The transmutation samples ( $^{129}\text{I}$ ,  $^{237}\text{Np}$ ,  $^{238}\text{Pu}$  and  $^{239}\text{Pu}$ ) were placed on the top of the 2<sup>nd</sup> section of the uranium blanket (fig.1) fixed on the special paper backplate ( $104 \times 140 \times 1 \text{ mm}^3$ ). In each experiment only one sample of each isotope was used plus one sample with  $^{127}\text{I}$ , which was irradiated to subtract its effect in  $^{129}\text{I}$  sample, which contains 15% of  $^{127}\text{I}$ . Also the  $^{238}\text{Pu}$  sample contains some other plutonium isotopes, mainly  $^{239}\text{Pu}$  (16.75 %). Radioactive materials are covered by aluminium (special duralumin alloy) with diameter of 34 mm. Some properties of the samples used in 2.52 GeV deuterons are given in table 1. Radioactive samples were manufactured by collaboration of three Russian nuclear research Institutes - the Leipunski Institute of Physics and Power Engineering at Obninsk, the Bochvar Institute at Moscow (VNIINN), and the "Maiak" Plant at Ozersk (Chelyabinsk region). Samples are periodically tested for hermetical properties, especially before and after irradiation by alpha activity on exterior surface testing. New Roman 12, 1.5 space, Justify alignment, including figures, tables and references

### 4. Activation detectors, solid state nuclear track detectors and samples of various technical materials

To determine the neutron field at the places where transmutation samples were located, activation threshold detectors as Al, Co, Cu, Y, Bi, Au where placed on the second

section of the blanket. SSNTDs were used for beam monitoring, investigation of high-energy neutron field ( $E > 30$  MeV) between blanket sections, determination of fission abundance and energy output of the blanket, thermal, epithermal and fast neutrons in the produced neutron field, etc. The investigations of technical properties of superconductor's materials, Hf, Zr, and epoxy (those are of a high importance for accelerator, reactor, and coupled engineering) have also performed.

*Table 1: Basic properties of radioactive samples for transmutation studies*

Sample	Decay type	Half-life, y	Weight, g	Purity, %
I-129	$\beta^-$	$15.7 \times 10^6$	0.591 0.121	85 I-129 15 I-127
Np-237	$\alpha$	$2.14 \times 10^6$	1.085	~100 Np-237
Pu-238	$\alpha$	87.7	0.0477	72.92 Pu-238 16.75 Pu-239 2.87 Pu-240 0.35 Pu-241 0.11 Pu-242
Pu-239	$\alpha$	$2.41 \times 10^4$	0.455	~100 Pu-239

### *System of He-3 counters*

The basic characteristics of He-3 proportional counter are summarized in Table 2. The measurement system, presented in Fig. 3, consists of a high voltage power supply, a preamplifier suitable for proportional counters (Canberra model 2006), an amplifier (Tennelec model TC205), and a computer based multichannel analyzer (Tennelec PCA III). He-3 was manufacture by LND INC., New York, USA. The system was calibrated using neutrons produced by the Tandem, Van de Graff accelerator facility at the Institute of Nuclear Physics, NCSR Demokritos (Athens, Greece) [26]. The detector was irradiated with mono-energetic neutrons in the energy range of 230 keV – 7.7 MeV, produced via  ${}^7\text{Li}(n,p){}^7\text{Be}$  and  ${}^2\text{H}(d,n){}^3\text{He}$  reactions. Due to the high pressure and its large dimensions the He-3 counter could be used effectively for measuring neutron energies up to about 7 MeV. A linear response with incident neutron energy was observed for neutron energies up to this energy, both for the full energy peak and the recoil peak. The resolution varied from 11% for thermal neutrons up to 4% for larger energies.

*Table 2. Basic characteristics of the counter.*

Detector	Press, atm	Gas content, %	Cathode material Thickness	Anode material diameter	Effective length, cm	Effective diameter, cm
He-3	6	${}^3\text{He}$ 64.7 Kr 33.3 CO <sub>2</sub> 2.0	Stainless Steel 304 / 0.089 cm	Tungsten / 0.025 mm	15	5

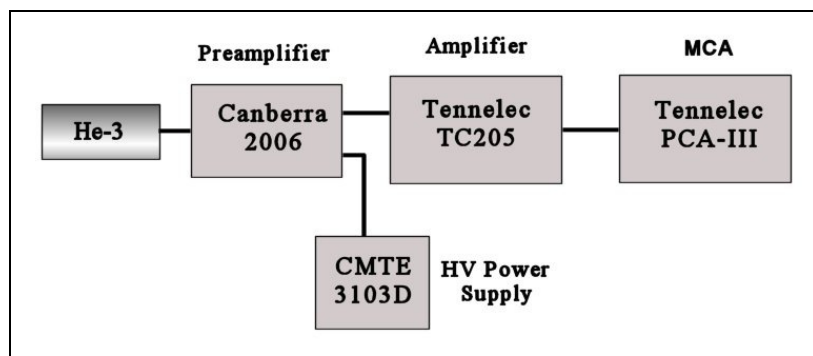

Fig. 3. Neutron counting system (see details in text).

The disadvantage of He-3 counters when they are used in high intensity neutron fields is the relatively high dead time they present, several tenths of  $\mu\text{s}$ . In order to avoid space charge effects or even paralyzation of the detector, the maximum count rate should be kept well below  $10^4$  cps. For this irradiation the motorized stage, which was specifically designed for holding and moving the counter during the experiment, was positioned at the maximum available distance, about 4.7 m from the center of U-blanket (fig. 4). The cylindrical side of the counter was covered with 1.2 mm Cd to minimize the contribution of scattered thermal neutrons, coming mainly from the concrete walls.

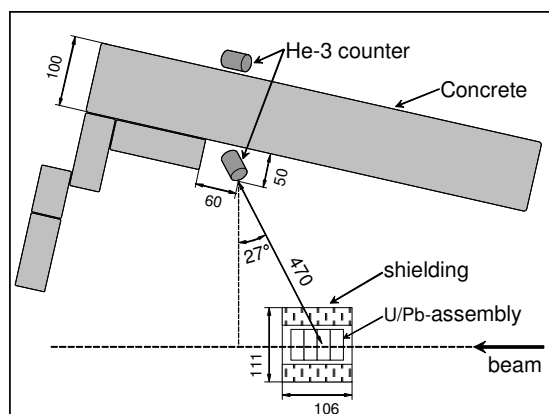

Fig. 4. Arrangement of the counter in respect to the beam direction and U/Pb-assembly of the setup “Energy plus Transmutation” (the distances are in cm).

### ***Gamma spectra measurement; installation description***

Measurement of activation threshold detectors, Al and Cu beam monitors, and transmutation samples were performed on HPGe detectors provided by Dzheleпов Laboratory of Nuclear Problems of JINR. Description of the main parameters of these detectors is given in table 3. Various geometry position as well as various filters of Pb, Cu, and Cd, were used depending on samples activities. Spectra measurements started few hours after the end of the irradiation and lasted for two weeks (depended from sample to samples). The HPGe detector

systems were calibrated using well-defined  $^{152}\text{Eu}$ ,  $^{154}\text{Eu}$ ,  $^{57}\text{Co}$ ,  $^{60}\text{Co}$ ,  $^{137}\text{Cs}$ ,  $^{88}\text{Y}$ ,  $^{228}\text{Th}$  radioactive sources.  $^{133}\text{Ba}$  source was also used for calibration in several gamma lines ranging from 80 keV up to 2600 keV. The obtained gamma spectra were analyzed and the net peak areas were calculated using the DEIMOS program [27]. All necessary corrections on possible coincidences and background contributions were done. Approximately five hundred of gamma-spectra were measured and analysed.

## 5. Results and discussion

This chapter gives some preliminary results of measurements with the  $^3\text{He}$  neutron counters, activation threshold detectors from  $^{27}\text{Al}$ ,  $^{87}\text{Y}$ ,  $^{197}\text{Au}$ , natural U foils, and from SSNT-detectors. Also the transmutation yields results of radioactive nuclear waste isotopes incineration are presented.

**(a) Methodical tests of neutron measurements using He-3 counters.** During the first part of the experiment, dedicated to irradiations of emulsions and track detectors, several spectra were collected. In all of them a distortion of the thermal peak (exothermic reaction  $^3\text{He}(n,p)^3\text{H}$  has energy  $Q=764$  keV) due to space charge effect is observed, in spite of the relatively smaller intensity of the beam. As an example, the spectra collected during the Polaroid exposure (1 pulse) and during the irradiation for emulsions (6 pulses) are presented in fig. 5. The count rate during these measurements was calculated to be in the range from 14 up to 17 kcps. For dosimetric purposes mainly, during the rest of the irradiation, the counter was placed behind the concrete in a symmetrical position (see Fig 4). The spectrum collected during this irradiation is also presented in Fig 5.

**(b) Transmutation of radioactive waste  $^{129}\text{I}$ ,  $^{237}\text{Np}$ ,  $^{238}\text{Pu}$  and  $^{239}\text{Pu}$  in the field of neutrons from ADS.** Reactions of radioactive samples – isotopes were irradiated by secondary neutrons generated by the spallation reactions of 2.52 GeV deuterons on lead target. The radioactive samples of  $^{129}\text{I}$ ,  $^{237}\text{Np}$  and stable  $^{127}\text{I}$  (for detail info see table 1 and fig.1) were irradiated on the top outside surface of the 2<sup>nd</sup> section of uranium blanket. Transmutation rates of the isotopes – yield of residual nuclei were investigated by gamma-spectroscopy methods. We obtain the data on absolute reaction rate (R-value – number of residual nuclei produced per atom of the sample, per one incident d or p) for some residual nuclei of our samples.  $^{127}\text{I}$  was used for subtraction of its part (15%) as a contamination of sample  $^{129}\text{I}$ . The results are given in tables 5 and 6 with the data on interaction of 2 GeV protons. Delay between first  $\gamma$ -spectra measurement and end of irradiation (cooling time) was 5 h for protons and 11 h for deuterons. As it is seen from the table 5, the results for deuterons 2.52 GeV (present work) and protons

2.0 GeV [12] are close with small deviations, what means that the main importance was the full energy of the input particles – deuterons and protons.

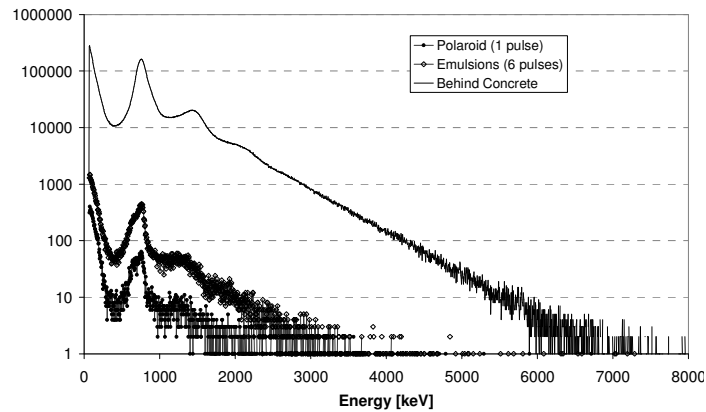

Fig. 5. Spectra collected during the irradiation of “Energy plus Transmutation” setup with deuteron beam at 2.52 GeV

Table 5. Residual nuclei observed in  $^{127}\text{I}$ ,  $^{129}\text{I}$ ,  $^{237}\text{Np}$  samples; R-value results for deuteron and proton beam

Residual nuclei	$T_{1/2}$	Deuterons 2.52 GeV (present work)	Protons 2.0 GeV [12]
I-127 sample, R - $10^{-29}$			
In-111	16.78 d	0.50(7)	0.38(10)
Te-119	16.03 h	1.15(18)	1.31(27)
Te-119m	4.70 d	1.15(26)	1.03(12)
I-121	2.12 h	3.87(100)	3.13(23)
Sb-122	2.72 d	1.24(15)	-
I-123	13.3 h	11.6(14)	13.0(10)
I-124	4.18 d	18.3(11)	19.0(10)
I-126	13.11 d	70.4(3)	81(4)
I-129 sample, R - $10^{-29}$			
Te-121	16.78 d	4.93(94)	-
I-124	4.18 d	4.38(125)	4.0(5)
I-126	13.11 d	10.8(25)	22.5(44)
I-130	12.36 h	816(40)	809(33)
Np-237 sample R - $10^{-26}$			
Zr-97	17.0 h	0.188(29)	0.159(8)
Mo-99	2.75 d	1.64(47)	-
Te-132	3.26 d	0.217(32)	0.147(11)
I-133	20.8 h	0.265(75)	0.182(28)
Np-238	2.12 d	17.0(8)	13.3(3)

But for  $^{237}\text{Np}$  the yield of residual nuclei for deuterons 2.52 GeV is systematically higher (near factor 1.3) than in case of 2.0 GeV protons.

The experimental values of reaction velocity  $R(A)$  and yield of residual nuclei  $B(A)$  were calculated by next formulas:



$$R(A) = \frac{N(A)}{n_s \cdot I_d}, \quad B(A) = \frac{N(A)}{m_s \cdot I_d}, \quad R(A) = B(A) \frac{A_s}{N_{Avo}} \quad (2)$$

where  $N(A)$  - number of nuclei of isotope A produced in an activation detector,  $n_s$  and  $m_s$  the number of atoms in the activation detector and its mass in grams,  $I_d$  deuteron fluence in the irradiation,  $N_{Avo}$  the number of Avogadro. Two important plutonium isotopes ( $^{238}\text{Pu}$  and  $^{239}\text{Pu}$ ) were irradiated also on the top of the second section of the target-blanket system (near the same place where  $^{237}\text{Np}$  and  $^{129}\text{I}$  and activation threshold samples were placed). Characteristics are given in table 6. As mentioned above, measurements of spectra were started about 11 hours after the end of irradiation. Due to such long cooling time, there is impossible to see produced isotopes with short lifetimes, which were observed in experiments with protons. It is obvious in the case of  $^{238}\text{Pu}$  target, in which only two products were found.

Table 6. Residual nuclei observed in  $^{238}\text{Pu}$  and  $^{239}\text{Pu}$  samples; R- and B-values results for deuteron beam 2.52 GeV

Residual nuclei	$T_{1/2}$	B ( $\Delta B$ ) x $10^5$	R ( $\Delta R$ ) x $10^{27}$
Pu-238 sample			
Zr-97	16.9 h	4.51(11)	15.6(4)
Xe-135	9.14 h	8.0(9)	29(4)
Pu-239 sample			
Ru-103	3.93 d	5.0(4)	19.8(17)
Sb-128	9.01 h	0.18(5)	0.72(22)
Te-132	3.2 d	4.3(4)	16.9(17)
I-133	20.8 h	6.8(7)	27(3)
I-135	6.57 h	4.6(8)	18(3)
Xe-135	9.14 h	3.0(8)	12(3)
Ba-140	12.75 d	5.2(6)	20.4(23)
Ce-143	33.04 h	3.6(4)	14.3(15)
Sr-91	9.63 h	2.6(4)	10.3(17)
Zr-97	16.9 h	5.3(4)	20.9(17)

### Measurements of neutron spatial-energy distribution using SSNTDs.

We will give here only the spatial-energy distribution of neutrons measured by SSNTDs, even though we have realized measurement using activation detectors. This part includes measurement of distribution of fission rates of  $^{\text{nat}}\text{Pb}$  and  $^{238}\text{U}$ , reactions of radiation capture of neutrons by  $^{238}\text{U}$ , and also a spectral index  $\frac{\sigma_{\text{capt}}^{238\text{U}}}{\sigma_f^{238\text{U}}}$  on radius of the U/Pb-assembly. Knowing the yield of fission products [28], it is possible to determine distribution of fission density of  $^{238}\text{U}$ . It is interesting to compare results received by two independent experimental methods among themselves and also with calculation results. It is obvious from

Fig. 9a, that results of measurement of radial distribution of number of fission reactions  $^{238}\text{U}$  determined by two experimental methods are in coincidence in the limit of experimental errors already since distance of 30 mm from longitudinal Pb target axis. Calculation also well describes fission process in a blanket material (natural uranium) and on periphery of the assembly

The spectral index characterizes a ratio between speeds of capture and fission of neutrons in a material uranium blanket. Results of experiment and calculation of a spectral index coincide in limits of experimental error (Fig. 10). The difference (1.5 times) is observed on periphery of the assembly.

As it was marked above, it speaks underestimation at calculations of influence of the neutrons moderated in biological shielding and reflected by biological shielding. It is obvious from Fig.10 that the number of  $^{238}\text{U}$  fissions exceeds number of radiation captures of neutrons in three times on the border of a lead target and blanket ( $R=32$  mm). Processes of radiation capture of neutrons begin to prevail with increasing radial distance, because in the process of moderation of neutrons as a result of not elastic collisions with nuclei of a material blanket. The developed combined track with  $\gamma$ -spectrometry technique of the spectral index determination provides reception of the information from the same sample by SSNTD methods (fission tracks density of  $^{238}\text{U}$ ) and by a  $\gamma$ -spectrometer method (on a  $\gamma$ -line nuclide  $^{239}\text{Np}$  with energy 277.6 keV) and which allows to measure spectral index with the error no more than 15 %. The developed technique will allow determination of  $^{239}\text{Pu}$  accumulation in the U-blanket. Experimental value of total mass of  $^{239}\text{Pu}$  accumulated in the setup is  $1.6(2)\cdot 10^{-8}$  g. We obtained also the value  $1.43\cdot 10^{-8}$  g using MCNPX code [29]. Calculation shows good agreement with experimental result within the limits of errors.

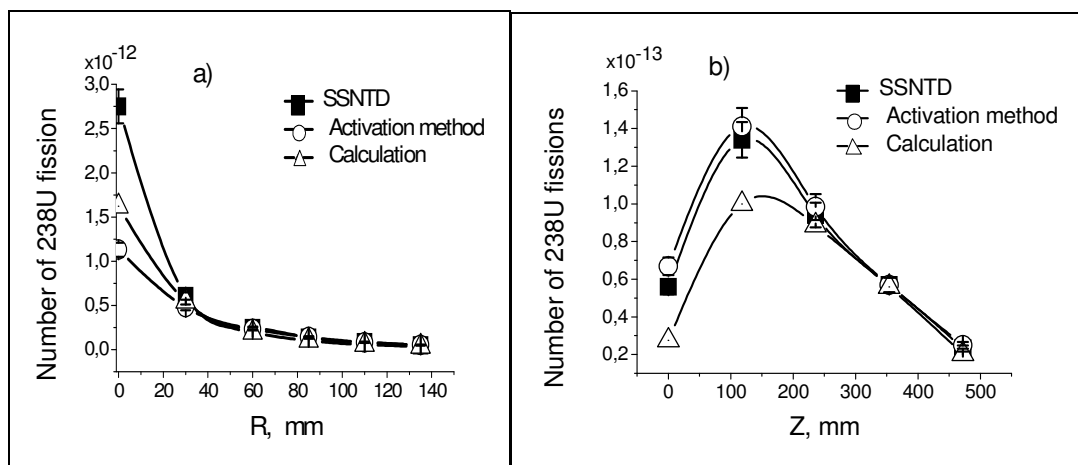

Fig. 6. Radial (distance  $Z=118$  mm) and axial (distances  $R=85$  mm from the target axis) distributions of number of fission reactions  $^{238}\text{U}$ . The data were normalized on one nucleus  $^{238}\text{U}$  and one incident deuteron.

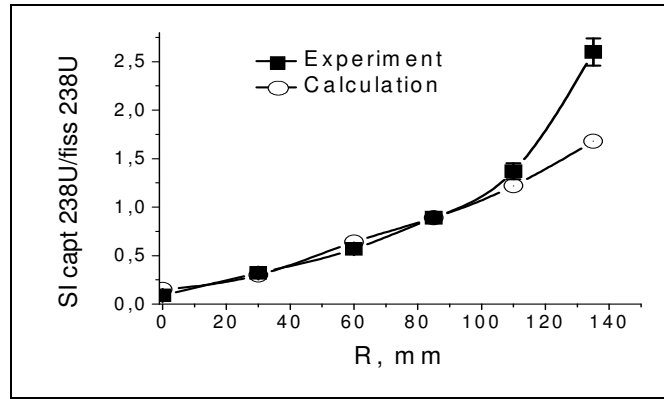

Fig. 7. Radial distribution of a spectral index (distance  $Z=118$  mm from the target front). Lines connecting the data points are drawn to guide the eye.

We have also measured fast neutron distribution along the U-blanket like in one previous experiments in which we have found the same intensity distribution and approximately the same intensities of fast neutrons in an irradiation of the same spallation source by a 1.5 GeV proton beam [30].

## 5. Conclusion

We performed the first experiment on investigations of transmutation (incineration) of radioactive waste atomic reactors ( $^{129}\text{I}$ ,  $^{237}\text{Np}$ ,  $^{238}\text{Pu}$  and  $^{239}\text{Pu}$ ) using deuterons beam with 2.52 GeV energy. Methodical measurements with the He-3 counters were done to determine the neutron fluences. Neutron spatial-energy distribution measured by SSNTDs is presented. Natural uranium foils were used to determine the  $(n,\gamma)$ -reaction rate along the target length and radius. Spectral indexes (capture to fission ratio) were also determined. Experimental results were compared with MCNPX simulations. Experimental and simulated values of spectral indexes agree well. Total experimental value of the  $^{239}\text{Pu}$  production in the whole blanket was estimated as  $1.6(2)\cdot 10^{-8}$  g, the theoretical prediction using MCNPX is  $1.43\cdot 10^{-8}$  g.

The measured experimental data complement our systematic obtained using proton beams with energies from 0.7 to 2.0 GeV.

In near future we will analyse fission cross-sections of different heavy targets induced by GeV protons and deuterons using SSNTDs

## Acknowledgements

Authors are grateful to Professors V. G. Kadyshevsky, A. N. Sissakian, G. D. Shirkov, S. Vokal and N. N. Agapov for their support of transmutation studies and Drs Yu.S.

Anisimov, S.V. Afanasev and P.I. Zarubin for their support of preparation and realization of the experiments using Nuclotron beams on the “Energy plus Transmutation” setup.

We thank the technical personnel of the Laboratory of High Energies JINR for providing effective operation of the accelerator during the irradiations of Pb- target with U-blanket.

Authors are grateful to members of Joint scientific seminar of LHE and LPP (scientific leader of seminar Prof V.A. Nikitin) for useful constructive discussions about results of this experiment.

Authors are grateful to the Ministry of Atomic Energy of the Russian Federation for providing the material to build the uranium blanket, the main part of the experimental setup „Energy plus Transmutation“. One of the authors ( S.Jokic) is grateful to the Professor Iosif Malaescu and Professor Agneta Balint of the West University, Timisoara for the invitation to participate on the Physics Conference TIM07.

### References

1. M.I.Krivopustov, D.Chultem. Exp. on Electronuclear Tech. and Transmutation of Nuclear Waste Using Synchrophasotron Beams. JINR News, 1998, 3(November), P. 27-30, Dubna.
2. M.I.Krivopustov, D.Chultem, Ts.Tumendelger et al. Modeling of the Electronuclear Method of Energy Prod. and Study of Rad. Waste Transmutation Using a Proton Beam of the JINR Synchrophasotron/Nuclotron. In «Research Program of the Laboratory of High Energies JINR». By editing of A.M.Baldin. Collection 99-266, Dubna, 1999, P. 135-139.
3. M.I.Krivopustov, D.Chultem, Ts.Tumendelger et al. “*On the First Exp. on Calorimetry of the Uranium Blanket of the Model U/Pb-Assembly of Electronuclear Installation “Energy plus transmutation” from the JINR Synchrophasotron at proton Energy 1.5 GeV*”. JINR - Preprint P1-2000-168, Dubna, 2000 // Journal “Kerntechnik”, 2003, V.68, P.48-55.
4. M.I. Krivopustov, D.Chultem, Tc.Tumendelger et al. Experimental Studies of Electronuclear Method of Energy Production and Transmutation of Radioactive Wastes Using Relativistic Beams from JINR Synchrophasotron/Nuclotron. Proc. XV Int. Seminar on High Energy Physics Problems, (Dubna, September, 2000). Dubna, 2001, V.2, P. 3-21.
5. M.I. Krivopustov, J. Adam, Yu.A. Batusov et al. Invest. of Neutron Sp. and Trans.  $^{129}\text{I}$ ,  $^{237}\text{Np}$  and other Nuclides with 1.5 GeV Protons from the Nucl. Using the Electr. Setup „En. plus Trans.”. JINR - Preprint E1-2004-79, Dubna, 2004 (Submitted in NIM A).
6. M.Zamani, M. Fragopoulou, M.Manolopoulou et al. “Neutron Generation in the New Transmutation Setup “Energy plus Transmutation” (Dubna). NIM A, 2003, V.508, P. 454.

7. S.Stoulos, M.Zamani, M.Manolopoulou et al. Appl. of Activation Method in Exp. Trans. Installations in Dubna. Applied Radiation and Isotopes, 2003, V.58, P.169-175.
8. S.Hashemi-Nezhad, R.Brandt, M.Krivopustov et al., Rad. Meas., 2003, V.36, P. 295-300.
9. A.M.Baldin, A.I.Malakhov, A.N.Sissakjan..Problems of Relyativistic Nuclear Physics and Multiple Particle Production. JINR - Communication R1-2001-106, Dubna, 2001 // J. Physics of Particles and Nuclei. 2001, V.32, Suppl. 1, P. s4-s30. b) A.D. Kovalenko et al. Main Results and Development plans. J. „Atomic energy“. 2002, V.93, P.479-485.
10. M.I.Krivopustov, R.Brandt, M.Heck et. al. First Exp. on Transmutation Studies of I-129 and Np-237 Using Relativistic Protons of 3.7 GeV. JINR - Preprint E1-97-59, Dubna, 1997. // Journal “Radioanalytical and Nuclear Chemistry”. 1997, V.222, P.267.
11. R.Brandt, M.Heck, M. I. Krivopustov et al. Trans. of Rad. Waste with the Help of Rel. Heavy I. JINR-Preprint, E1-97-349, Dubna, 1997, J.“Kerntechnik”. 1998,V.63,P.167-172.
12. J.Adam, K.Katovsky et al. Trans. of <sup>129</sup>I, <sup>237</sup>Np, <sup>238</sup>Pu and <sup>241</sup>Am Using Neutrons Produced in Target – Blanket System “Energy plus Transmutation” Bombarded by 2 GeV Relativistic Protons. In Proc. «Int. Conf. on Nuclear Data for Sc. and Tech.» (Sept. 26 – October 01, 2004, Santa Fe, New Mexico, USA). New York, 2005, V.2, P.1560-1563.
13. M.I. Krivopustov et al. (for Collaboration “Energy plus Trans.” all Inst. and Authors). Invest. of Neutron Trans. of Rad. Waste of Atomic Reactors <sup>129</sup>I, <sup>237</sup>Np, <sup>238</sup>Pu, <sup>239</sup>Pu and <sup>241</sup>Am at the Setup „Energy plus Transmutation” with Proton and Deuteron Beams with Energies from 0.7 to 2.5 GeV of JINR Synchrophasotron / Nuclotron (Dubna). In Proc. XIV. Int. Sem. on Int. of Neutrons with Nuclei, (Dubna, May 25-30, 2006), in print.
14. J.Adam, K.Katovsky et al. Transmutation of <sup>129</sup>I, <sup>237</sup>Np, <sup>238</sup>Pu, <sup>239</sup>Pu and <sup>241</sup>Am Using Neutron Produced in Pb-Target with natU-Blanket Sys. “Energy plus Trans. by Rel. Protons. Ab. of LVI Nat. Conf. on Nuclear Physics (8-12 September, 2006, Sarov, Russia).
15. J.Adam, K.Katovsky et al. Int. of Radioactive Nuclei <sup>129</sup>I, <sup>237</sup>Np, <sup>238</sup>Pu and <sup>239</sup>Pu and stable <sup>127</sup>I with the Secondary Neutrons from the Pb-Target with U-Blanket System “Energy plus Transmutation” Irradiated by 2.52 GeV Deuterons. Books of Abstracts LVI Conference on Nuclear Physics.(8-12 September, 2006, Sarov, Russia). Proc. in print).
16. M.I.Krivopustov et al.(for Coll. “Energy plus Transmutation”. All Inst. and Univ. and all Authors). “Inv. of the Neutron Field of Pb-target with natU-blanket and Radioactive Waste Trans. of I-129, Np-237, Pu-238, Pu-239 and Am-241 on Proton Beam with Energies from 0.7 to 2.0 GeV on Synchrophasotron / Nuclotron JINR (Dubna)”. Book of Abs. XVIII Int. Baldin Sem. on High Energy Physics Problems. Rel. Nuclear Physics and Quantum Chromodynamics. (Sept. 25-30, 2006, Dubna, Russia). (Proc. in print).

17. M.I.Krivopustov et al. (for Coll. "Energy plus Transmutation". All Inst. and Univ. and all Authors). "About the First Exp. at Deuteron Beam Nuclotron JINR with Energy 2.52 GeV on Invest. Radioactive Waste Trans. and on Neutrons Gen. in natU/Pb-assembly". Abs. of book XVIII Int. Baldin Sem. on High Energies Phys. Problems. Rel. Nuclear Phys. and Quantum Chromodynamics (September 25-30, 2006, Dubna, Russia). (Proc. in print).
18. C. D. Bowman, E. D. Arthur, P. W. Lisowski et al. Nuclear energy generation and waste transmutation using an accelerator-driven intense thermal neutron source Nuclear Instruments and Methods in Physics Research A. 1992, V.320. P.336-367.
19. C. Rubbia, J. A. Rubio, S. Buano et al. Conceptual design of a fast neutron operated high power energy amplifier CERN. Report CERN/AT/95-44 (ET).
20. H. Nifenecker; S. David, J.M. Loiseaux. A. Giorni Hybrid nuclear reactors // Progress in Particle and Nuclear Physics. 1999, V.43, P.683-827.
21. C. Rubbia, J. Aleixandre, S. Andriamonje et al. A Eu. Roadmap for Dev. Ac. Driven Sys. for Nuc. Waste Inc. ISBN 88-8286-008-6, 2001; [inrwww.fzk.de/adsroadmap.html](http://inrwww.fzk.de/adsroadmap.html)
22. A. Abanades, J. Aleixandre, S. Andriamonje et al/ Nuclear Instruments and Methods in Physics Research. 2002, V.478, P. 577-730.
23. R. Brandt, M.I. Krivopustov, W. Westmeier et al. J. "Kerntechnik". 2004, V.69, P.37-50.
24. K.D. Tolstov, V.A. Voronko, V.Ya. Migalenyia et al. Generation Neutrons in Thick Lead Target. Journal "Atomic Energy". 1990, V.68, P.449-454. // Energy Generation Neutrons light Nuclei in Lead slot. JINR - Rapid Comm. 2(53), Dubna, 1992, P 17-25.
25. R.G. Vassilkov, V.I. Gol'danskii, V.V. Orlov Electronuclear Method Generation Neutrons. // Journal "Atomic Energy". 1970, V.29, P.151-187 // About Electronuclear breeding. // Journal Succ. Phys. Sci., 1983, V.139, P.435-478.
26. M. Manolopoulou, M. Fragopoulou, M. Zamani et al. Studies on the response of He-3 and He-4 prop. counters to monoenergetic fast neutrons. NIM A, 2006, V.562, P.371.
27. J. Frána. Program DEIMOS 32 for Gamma Ray Spectra Evaluation. Journal "Radioanalytical and Nuclear Chemistry". 2003, V.257, P.583-587.
28. V. M Gorbachev, Yu. S. Zamyatin, A.A. Lbov. "Interaction Ray with heavy element and fission nuclei". Moscow, Atomizdat, 1978.
29. L. W. Hendricks, G. M. McKinney, L. S. Waters et al. MCNPX, VERSION 2.5.e, Report No. LA-UR-04-0569, Los Alamos National Laboratory, USA, February 2004.
30. M. Zamani, M. Manolopoulou, M. Fragopoulou et al.. "A Spallation neutron source based on Pb target surrounded by U blanket "Proc. Of the 23-rd Intern. Conf. SSNTD (Sept. 11-15, 2006, Bijing, China). (In press in Rad. Measurements).